

Operation Manual

VIESSMANN

VITOWELL EASY D1
Instant Water Heater

VITOWELL EASY D1



Parts Identifications

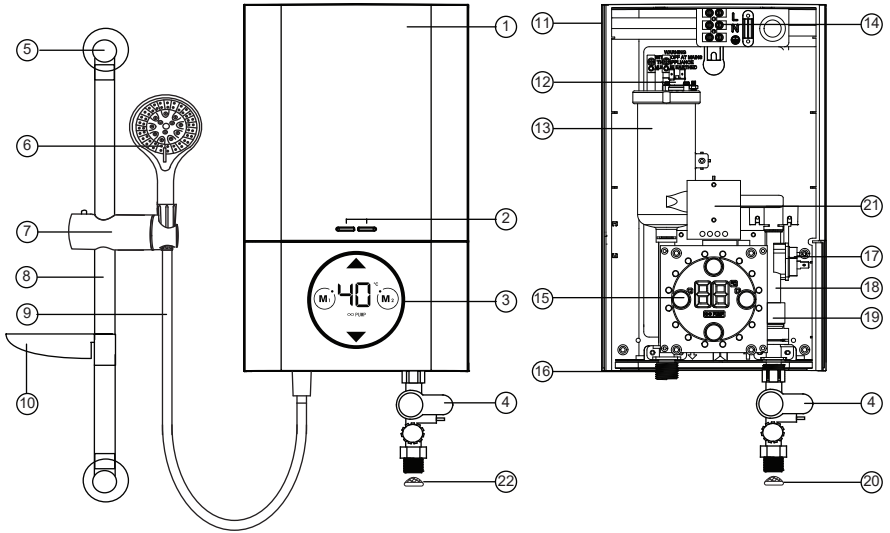

- | | |
|-----------------------------|-----------------------------|
| 1. Front Cover | 12. Thermostat |
| 2. LED Indicators | 13. Heater Tank |
| 3. Main Display | 14. Terminal Block |
| 4. Stop Valve | 15. Main PCB Board |
| 5. Rail Support | 16. Water Outlet Connection |
| 6. Handshower | 17. TRIAC |
| 7. Adjustable Shower Holder | 18. Water Inlet Connection |
| 8. Slider Rail | 19. Flow Sensor |
| 9. PVC Hose | 20. Mesh Filter |
| 10. Soap Tray | 21. LED Board |
| 11. Heater Base | |

Important Safety Information

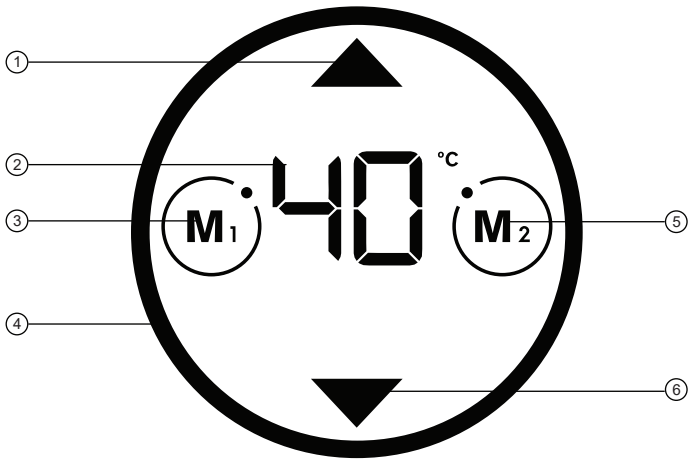

1. Up Button
2. Temperature Indicator
3. Memory Button, M1
4. LED Light
5. Memory Button, M2
6. Down Button

NOTES:

(*) Memory includes temperature.

Buttons are 100% lit when unit is ON and buttons are not lit when unit is OFF or standby mode.

The display and buttons should not blink unless there is an urgent message/ error/ alarm. During normal operation, all interaction shows without the screen segments blinking.

Important Safety Information

■ Products manufactured by us are safe provided they are installed, used and maintained in good working order in accordance with our instructions and recommendations. Always refer to this manual if you have any doubt.

■ The appliance must be earthed. Improper grounding could cause electric shock.

■ If any of the following conditions occur, immediately switch off the mains and contact the sales agent for repair. Never attempt to repair the unit yourself.

-If the heater begins to make an odd noise, smell or smoke..

-Water temperature can not be controlled.

-If the instant water heater shows signs of a distinct change in performance.

-If found water leakage from inside.

■ The appliance is not intended for use by person (including children) with reduced physical, sensory or mental capabilities, or lack of experience and knowledge, unless they have been given supervision responsible for their safety. Children should be supervised at all times when using the unit to ensure that they do not play with the appliance.

User is advised to test and adjust the water temperature before showering.

■ In times of lightning/thunder, switch off the electric supply to the instant water heater in advance to protect the instant water heater against possible damage.

■ Metallic/chrome hose and conductive control valve shall not be used. (Malaysia only)

Note: When removing the instant water heater from package, small amount of water may be found inside. This is normal as the unit is tested during manufacturing process.



■ Installation must be carried out by a qualified personnel and in compliance to the local authority regulations.

■ This instant water heater must be permanently connected to the direct main current supply. The use of a plug and socket is not recommended.

■ For the correct size of wire conductor corresponding to different electrical loading, please refer to Table 1.

■ This instant water heater operates at a minimum water flow rate of 2.0 L/min and maximum working pressure of 6 bars. For direct connection to the water tank, the heater must have a minimum distance of 1.0m below the water tank.

■ This instant water heater will not function if there is insufficient water flow (min 2.0 L/min) to trigger the flow switch.

■ The thermostat will automatically cut off the power supply if it has sensed an abnormal rise in water outlet temperature.

Heater Unit Installation

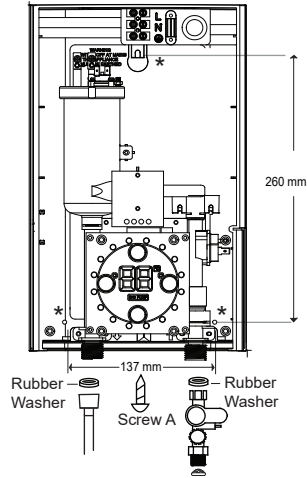
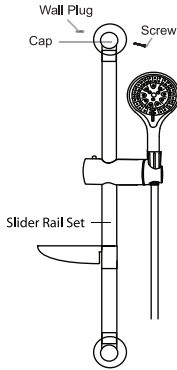

- Select a suitable position in the bathroom.
- Remove the Screw A at the bottom of the unit.
- Remove the Front Cover from the bottom and then lift up the Front Cover.
- Mark 3 Screw points of the Heater Base on the wall. (Refer * marking)
- The Instant Water Heater position should be 1.5m above the bathroom floor.
- Mark 2 screw points of the Slider Rail beside the heater. It is recommended that the top of the portion is in level with the top of Instant Water Heater.
- Use 6mm diameter drill and make the wall plug holes in depth of 34mm.
- Insert the wall plugs and mount the Instant Water Heater firmly in position with the screws provided.
- Insert the Shower Holder and Soap Tray into the Slider Rail.
- Mount the Slider Rail to the Rail Bracket.
- Remove the cap from the Rail Bracket and screw the Bracket to marked position. Replace the cap.

Plumbing Procedure



This Instant Water Heater is a single point system and the “Water Outlet” can only be fitted to the PVC Hose and Handshower set provided. NO CONTROL VALVE OR FITTING CAN BE FITTED TO THE WATER OUTLET.

- Connect the Stop Valve to the Water Inlet with washer. Use correct tools to tighten the connection and be careful not to over tighten and damage the plastic nut.
- Connect the incoming water piping to the Stop Valve (1/2” BSP). Make sure to put the Mesh Filter between Stop Valve and incoming water piping.
- If in any case, the Stop Valve is not used or omitted, make sure to put the Mesh Filter between the heater unit inlet pipe and incoming water pipe.
- Turn on the water mains to drain out all plumbing dirts, at the same time fill up the heater tank. THE HEATER TANK MUST BE FILLED UP WITH WATER BEFORE TURNING ON THE ELECTRICITY SUPPLY TO PREVENT ANY DRY BURNT DAMAGE TO THE HEATING ELEMENT.
- Connect the PVC Hose and Handshower to the outlet of the Instant Water Heater, be sure to put in the Washer.
- Hook the Handshower to the Sliding Rail Shower Holder and adjust to your ideal position.
- Check if any water leakage.
- Do not use white tape during piping installation.



- THE WATER INLET AND OUTLET MUST BE INSTALLED CORRECTLY , OTHERWISE IT MAY CAUSE A DAMAGE TO THE HEATING ELEMENT.
- DO NOT APPLY PLUMBING CEMENT ON CONNECTION. WHENEVER NECESSARY, USE ONLY THREAD OR SEALING TAPE.

Electrical Installation

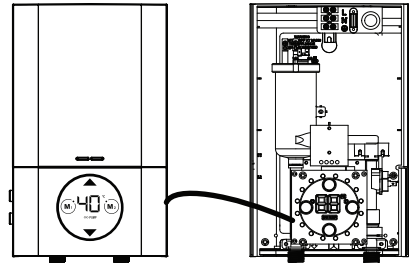
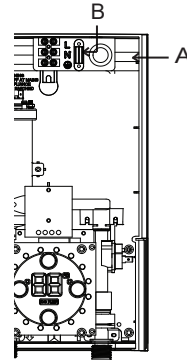
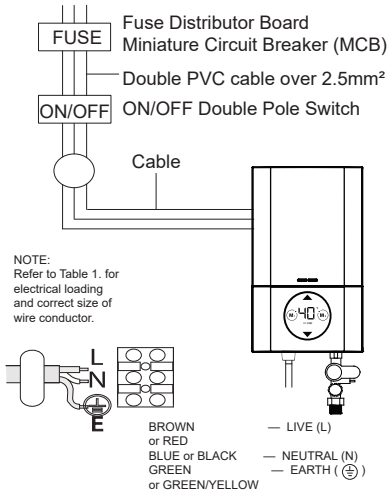

PROCEDURE:

Insert the cable through 'A' for side entry or 'B' for wall embedded cable by cutting a hole through the source cord rubber holder.

Connect the cable to Terminal Block and fully tighten them as follow

BROWN or RED — LIVE (L)
BLUE or BLACK — NEUTRAL (N)
GREEN/YELLOW — EARTH (⊕)

When replace back the Front Cover, please take note the below procedure:

- Connect the LED display cable from Front Cover to the Main Control PCB. Clamp the cable to the correct position. CHECK IF THE WIRING CONNECTION IS CORRECT and replace the cover.
- Fix back the screw 'A'.



This appliance must be EARTHED. Improper grounding could cause electrical shock. Remember to SWITCH OFF at mains before carrying out any electrical work.

Refer to the Electrical Loading Table for the correct cable size. Use double coated flexible cable having nominal cross-sectional area 2.5mm².

Lead the power cable from the MCB to a "ON/OFF" double pole linked switch having a contact separation of at least 3mm in all poles outside the bathroom, then lead a cable connected to Terminal Block inside the unit.

Test Operation

Test Run

Before switching ON electricity supply, please check the electrical wiring connection properly to the Electric Water Heater.



■ Starting Mode

The icons will blink twice (infinity, pump, two white dot led)



■ When the 3 in 1 Stop Valve is turned on

Last used setting will be activate if the 3 in 1 Stop Valve is turned on.

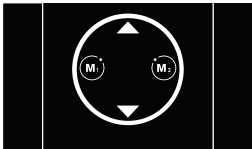

When 3 in 1 Stop Valve is turned off, Electric Water Heater goes to pre-standby.

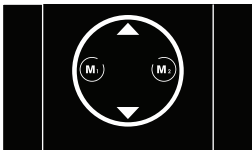

If the 3 in 1 Stop Valve is not turned ON, after 5 minutes will go to standby mode.

Changing Temperature Manually

The temperature can be gradually controlled by pressing either UP or DOWN button.



■ Press UP button

Temperature increases.



■ Press and hold UP button for 2 sec.

Temperature increases at faster speed up to the maximum 45°C.



■ Press DOWN button.

Temperature decreases.



■ Press and hold DOWN button for 2 sec.

Temperature decreases at faster speed down to 32°C and stop autoscroll.

If the setting reached 32°C, presses DOWN button one more time will trigger the cold water function.

Test Operation

COLD SHOWER SHORTCUT

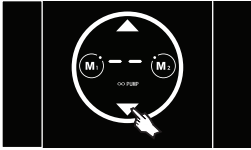

■ Water heater is running

After 32°C pressed display changed to two lines.

Electric Water Heater turns off the heating element.

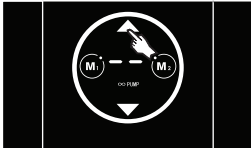

■ Cold setting deactivated.

Presses the UP button then display will go back to 32°C setting.



■ Cold setting deactivated (Alternative)

Pressing the M1/ M2 will go to memory setting.

Pressing UP button will adjust setting temperature.

Test Operation

MEMORY SETTING

This Electric Water Heater allows user to store up to 2 desired settings (M1/M2) for easy access.



■ Memory Function

After selecting the desired temperature, press the memory button (either M1,M2) and hold for 3 seconds to store.

Memory indicator will lights up and beeps once to indicate the setting has been stored.



■ Memory selection

User may select a desired stored setting by pressing either M1,M2.



■ Deactivate the memory function

Press any button except your current selected memory (M1,M2) to exit your selected memory.

The memory indicator will appear in the event that the combination manual selection for the temperature value are the same as stored memory, the memory indicator will lights up.

Test Operation

DEMO FUNCTION

Press and hold M1, UP, DOWN at the same time, buzzer will buzz twice to indicate DEMO mode has successfully activated.



■ Demo mode

Icon **88** will display “V0” version code for 1 second, temperature display will show cold water “ ” next, 32°C will keep rising by 1°C until it reaches 45°C. If Demo mode does not exit, buzzer will buzz once and repeat the above display.

Press and hold M1, UP, DOWN again, buzzer will buzz twice to exit DEMO mode.

During DEMO mode, all operations are invalid. Reconnecting power supply can exit DEMO function.

■ Outlet water temperature display function

This heater is able to show actual temperature.

While heater is working, press and hold “M1, M2, UP” button together, buzzer will buzz twice, after 3 seconds the thermistor actual temperature will show on temperature display.

Switch off water to exit or press and hold “M1, M2, UP” button all together to exit.

Electrical Loading Table

Voltage (AC)	Power (kW)	Current (A)	Minimum Conductor Size (csa)			On/Off Switch (A)	Fuse / MCB (A)
			mm ²	Conduit Cable	Flexible Cable		
240~50/60Hz	3.6 <small>(Malaysia/Modal)</small>	15.0	4.0	7 / 0.85 mm	56 / 0.30 mm	20	20
230~50/60Hz	3.3	14.4	2.5	7 / 0.67 mm	50 / 0.25 mm	20	20
220~50/60Hz	2.4	10.9	2.5	7 / 0.67 mm	50 / 0.25 mm	20	20
	3.5	15.9	2.5	7 / 0.67 mm	56 / 0.25 mm	20	20
	4.5	20.5	2.5	7 / 0.67 mm	56 / 0.25 mm	32	32
	6.0	27.3	4.0	7 / 0.85 mm	56 / 0.30 mm	32	32

Test Run

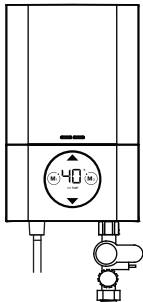

- Turn on the water supply and Stop Valve, the water will flow through the Handshower.

- Switch on the electrical supply.

Turn the Temperature Control Knob to 'ON', the Red Indicator light (Power) will turn on, hot water will flow out within a few seconds. The more Temperature Control Knob being turned in clockwise direction, the hotter the shower is.

- The shower might not be hot enough even at 'MAX' position if incoming water supply from the mains is too cold or pressure water is too high. In this case, you may adjust the Stop Valve to reduce the water inflow in order to get the desired showering temperature.

- Switch OFF the electricity supply after shower.

Handshower Spray Action



This innovative adjustable Handshower has 5 different spray actions (STANDARD, SOOTHE, JUMBO, MIX, MASSAGE). The actions are described as above.



Clean the Handshower Head holes by using the soft brush from time to time. Recommended once a week. Note: Take care not to damage the holes of the Handshower Head during cleaning.

Maintainance

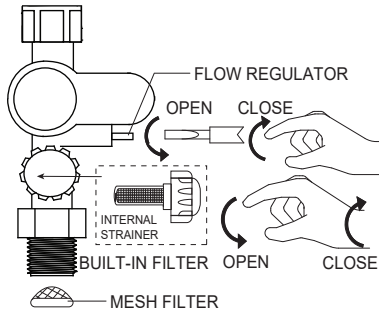

Read the section 'IMPORTANT SAFETY INFORMATION' first.

■ CLEANING PRECAUTION!

Do not use thinner, alcohol, petrol or any other organic solution to clean the set, use only a damp cloth with mild detergent.



■ **CLEAN THE FILTER REGULARLY.** There are two filters located at the stop valve, one is Mesh Filter (installed at the incoming water supply), another one is the built-in filter as shown.

■ Clean the Mesh Filter regularly to prevent blockage. Remove the built-in filter by turning anti-clockwise as shown. Take out the Filter and flush it with water to remove any trapped sediments.

Troubleshooting

Problem/Symptom	Cause	Action/Cure
Electric Water Heater fail to operate, no power.	Interrupted power supply.	Check the wire connection and main power supply. If it still fail to operate, contact Viessmann Customer Service Call Centre.
	Electric Water Heater malfunction.	Check other appliances are having same phenomenal and contact local Electricity Supply Company. If it still fail to operate, contact Viessmann Customer Service Call Centre.
Water too hot.	Not enough water flowing through the shower.	Increase flow rate via water flow controller or 3 in 1 Stop valve.
		Blocked of shower head - clean or replace.
	Blockage in water supply.	Check if 3 in 1 stop valve are fully turns on. Cleaning Mesh Filter and Built In Filter.
	Incoming water temperature too high.	Reduce the setting temperature via temperature adjuster.
Water hot after close and reopen of 3 in 1 Stop Valve or Water Tap.	Water temperature higher than set temperature when 3 in 1 Stop Valve or Water Tap is OFF a while and reopen again.	Avoid shower with water output in that period. Let the water flow few seconds before continue bathing.
Water too cool or cold.	Too much water flow.	Reduce flow rate via water flow controller or 3 in 1 Stop valve.
	Water pressure below minimum required and water heater not function.	Check water supply from mains or tank fed. If tank fed, replumb to mains water supply and check if the water pressure is enough. If mains fed, make sure that mains 3 in 1 stop valve is fully turns on and that there are no other restrictions in the water supply while water heater is in use.

Troubleshooting

Problem/Symptom	Cause	Action/Cure
Electric Water Heater no power.	Incoming water flow too low.	Adjust the 3 in 1 Stop valve.
	Electrical malfunction of Electric Water Heater.	Contact Viessmann Customer Service Call Centre. 
	Safety Thermostat cut-out operated.	Safety Thermostat cut-out operated. Contact Viessmann Customer Service Call Centre.
Water flow too low.	3 in 1 Stop Valve Filter/Mesh Filter blocked.	Clean the filter.
	3 in 1 Stop Valve not fully open.	Open 3 in 1 Stop Valve to desire flow rate.
	Water supply insufficient.	Check house water supply.
Display E1 	Electrical leak can be triggered at any time during usage or standby.	Contact Viessmann Customer Service Call Centre.
Display E2 	The E2 and thermistor icon will appear and blink on screen in synchronisation with the beep due to thermistor Error.	Contact Viessmann Customer Service Call Centre.

NOTES

It is advised all electrical maintenance/repairs to the shower should be carried out by a suitably qualified person. In the unlikely event of Electric Water

Heater failure other than detailed in the fault finding page, please contact Viessmann Customer Service Call Centre for advice.

Wiring Diagram

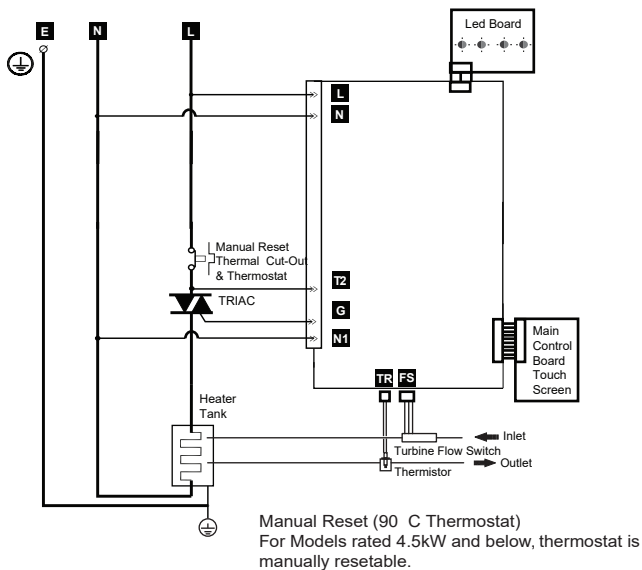

Electrical Specification

TYPE	ELECTRONIC POWER CONTROL
ELECTRICAL LOADING	3.3kW 230Va.c. 50/60Hz
Min. WATER FLOW RATE	2 Liter / min.
Min. INLET WATER PRESSURE	0.1 Bar (10kPa)
Max. INLET WATER PRESSURE	6 Bar (0.6MPa)
WATER CONNECTION	1/2" BSP SINGLE POINT SYSTEM
DIMENSIONS	210 x 343 x 87 mm
WEIGHT	1.6 Kg (No Pump)

Note : The specification, actual product's cosmetic design and accessories parts shown are correct at the time of printing and may be subjected to change without prior notice.

VISSMANN
VITOWELL



CUSTOMER CARE
+65 6970 8411

VISSMANN GROUP
VISSMANNSTRASSE 1, 35108 ALLENDORF (EDER),
GERMANY

REGIONAL OFFICE
VISSMANN SINGAPORE PTE.LTD
25 INTERNATIONAL BUSINESS PARK #04-01/02
GERMAN CENTRE
SINGAPORE (609916)